

# Xirtec140

PVC PROCESS PIPING SYSTEM

# CORZAN™

CPVC PROCESS PIPING SYSTEM



## INDUSTRIAL SYSTEMS

### VINYL PROCESS PIPING SYSTEMS

Complete systems of pipe, valves and fittings designed, manufactured and backed by one company.

**IPEX. Your Industrial Specialist.**  
We build tough products for tough environments™

**IPEX**  
Committed to Excellence

# The IPEX System Advantage

Introducing IPEX vinyl process piping systems.

A complete line of pipe, fittings, flanges, strainers and valves to meet all your process system requirements.

IPEX developed the Xirtec™140 (PVC) and Corzan™ (CPVC) systems to meet industry demands for a complete PVF package that is designed, produced and backed by a single manufacturer. These systems are engineered and manufactured to IPEX's strict quality, performance and dimensional standards, and therefore eliminate the problems inherent in purchasing and installing piping system components manufactured by several different companies.

IPEX high-performance vinyl systems are designed to meet the temperature, pressure and size requirements of piping systems used in chemical processes and other industrial applications. They feature outstanding resistance to photodegradation, creep stress and immunity to oxidation, and are exceptionally suited for use with a wide range of acids, alcohols, salts and halogens. The perfect extended service, low maintenance alternative to common and exotic metal systems.

Xirtec140 and Corzan pipe and fittings are available in Schedule 40 and Schedule 80, IPS. Pipe and fittings are also available in cast iron sizes.

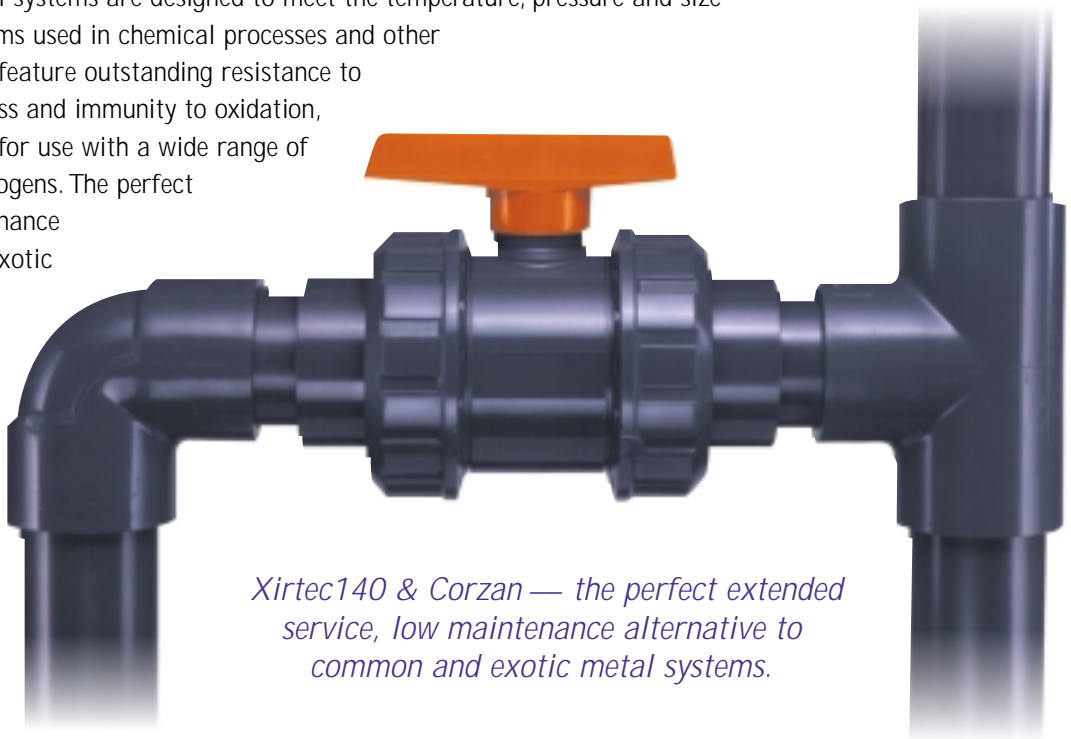

*Xirtec140 & Corzan — the perfect extended service, low maintenance alternative to common and exotic metal systems.*

## Designed, Manufactured and Backed by IPEX

For more than 50 years, IPEX has been manufacturing thermoplastic pipe, valves and fittings — complete system solutions to meet the challenges of industry and construction. We formulate many of our own compounds, maintain strict quality control, and market and distribute our products throughout North America. IPEX manufactures systems from a broad range of materials including PVC, CPVC, PP, ABS, PVDF, PEX, PE and composite materials. Our total systems approach means you can be confident that all the material you need is designed, manufactured and backed by the same company. One source to stand behind you and your complete system.

# Process Piping Applications

IPEX supplies PVC and CPVC systems for a broad range of industrial applications.

- Plant chemical distribution lines
- Water & wastewater
- Acid systems for refineries, pickling lines and plating shops
- Chlorine injection, chlorine dioxide, and chloralkali plant piping
- Steel wire plants
- Battery manufacturing
- Bleach lines in textile and paper mills
- Alum and caustic handling systems
- Circuit board manufacturing
- Semiconductor
- Pharmaceutical
- Cooling water and cooling tower systems
- Tailing and slurry lines
- Washwater recovery systems
- Plant water supply
- Brine and seawater systems
- Fish farming
- Waterworks
- Aquariums and swimming pools
- Irrigation systems in golf courses, greenhouses, etc.



## Xirtec<sup>140</sup> PVC (Polyvinyl Chloride) Systems

PVC is the most frequently specified of all thermoplastic piping materials and has been used successfully for over 60 years. PVC is characterized by distinctive physical properties, and is resistant to corrosion and chemical attack by acids, alkalis, salt solutions and many other chemicals. Of the various types and grades of PVC used in plastic piping, Xirtec140 uses Type 1, Grade 1 PVC (Cell Classification 12454) conforming to ASTM D 1784. The maximum service temperature for Xirtec140 is 140°F in pressure applications and 180°F in intermittent drainage applications. With a design stress of 2000 psi @ 73°F, PVC used in Xirtec has one of the highest long-term strengths of all major thermoplastic material used for piping. Xirtec piping is joined by solvent cementing, threading, flanging, grooving, gasketed joints, or mechanical joints.

## Corzan CPVC (Chlorinated PVC) Systems

CPVC (Cell Classification 23447-B) conforming to ASTM D 1784 has physical properties at 73°F similar to those of PVC; its chemical resistance is similar to or generally better than that of PVC. With a design stress of 2000 psi and maximum service temperature of 210°F, Corzan has proved to be an excellent piping system for hot corrosive liquids, hot and cold water distribution and similar applications above the temperature range of Xirtec140. Corzan piping is joined by solvent cementing, threading, flanging or grooved joints.



# The IPEX Advantage

IPEX systems offer the unique combination of light weight, flexibility, durability and exceptional corrosion resistance.



## Lower Installation Costs, Easy Handling

In addition to a lower material cost, Xirtec & Corzan pipe can significantly reduce labor and transportation costs on a typical installation. The reason? They are lightweight, easily handled, stored, cut and joined. And, heavy equipment used to install metallic and other piping systems are not required, thereby reducing project costs.



## Extended Life

Xirtec PVC & Corzan CPVC are fundamentally ageless and impervious to normal weather conditions. These piping components in uninterrupted service and in a variety of demanding industrial applications have operated successfully for over 40 years. Once properly selected for the application and correctly installed, IPEX vinyl systems provide years of maintenance-free service. They will not rust, pit, scale or corrode on either interior or exterior surfaces. Unlike other types of piping, Xirtec140 and Corzan systems are not adversely affected by environmental conditions.



## Superior Underground Performance

Xirtec140 and Corzan CPVC are immune to damage from naturally corrosive soil conditions as well as electrochemical and galvanic corrosion. This is particularly advantageous in underground installations where galvanic reaction often causes damage to metal piping products. Noncorroding properties ensure improved flow, lower maintenance costs and longer performance life.



## Exceptional Chemical Resistance

The IPEX vinyl systems, including pipe, valves and fittings, provide outstanding resistance to a wide range of chemicals such as most acids, alcohols, alkalies, salt solutions, halogens and more. However, chemical resistance is a function of concentration, pressure and temperature. For specific applications, see the IPEX Chemical Resistance Guide.



## Improved Flow

Xirtec140 and Corzan have a substantially lower Roughness Factor than metal and other materials, and since they do not rust, pit, scale or corrode, the interior walls remain smooth in virtually any service. This high carrying capacity may permit the use of flatter grades or smaller diameter pipe.



## Potable Water Approved

Xirtec140 polyvinyl chloride (PVC) and Corzan chlorinated polyvinyl chloride (CPVC) are suitable for use with potable water as listed with the National Sanitation Foundation (NSF) and CSA International. Both systems meet or exceed all applicable standards.

## Exceptional Temperature Range

IPEX vinyl systems are designed to meet a broad range of service temperatures. Xirtec140 has a recommended maximum service temperature of 140°F in pressure, 180°F in drainage; Corzan has a maximum service temperature of 210°F.

## Lower Thermal Conductivity

With a low thermal conductivity factor, IPEX vinyl systems have less heat loss or gain, thus sustaining service temperature more efficiently than metal piping. As a result, pipe insulation is often not required.

## Environmentally Responsible

With energy conservation a prime concern, you can rely on the fact that IPEX's manufacturing process for Xirtec & Corzan piping materials requires less than half the energy needed to produce the equivalent size of carbon steel or steel alloy materials.

## Unmatched Reliability

At IPEX, we take pride in manufacturing the widest range of thermoplastic piping systems available, supplemented by experienced personnel in design, drafting, mold building, quality control, distribution and marketing. All piping systems are produced to the strictest internal quality control specifications and subjected to independent regulatory standards.

# Pipe

IPEX features one of the most comprehensive ranges of thermoplastic pipe for today's industrial applications. Available in Schedule 40 and 80 with sizes ranging from 1/4" to 24", as well as SDR in sizes ranging from 1/2" to 48", IPEX vinyl pressure pipe exceeds the most stringent and demanding standards set by key standards organizations including ASTM, AWWA, CSA and NSF, to name a few.

But *unlike* almost all other pipe manufacturers in the world IPEX's commitment to quality doesn't stop at the end of the manufacturing process or at our pipe yard. Xirtec140 and Corzan pipe are part of complete PVF systems. Dimensional matching, compatibility of compounds, chemical, physical and thermal properties and system accountability make IPEX pipe a key component of the high-performance Xirtec140 and Corzan systems.

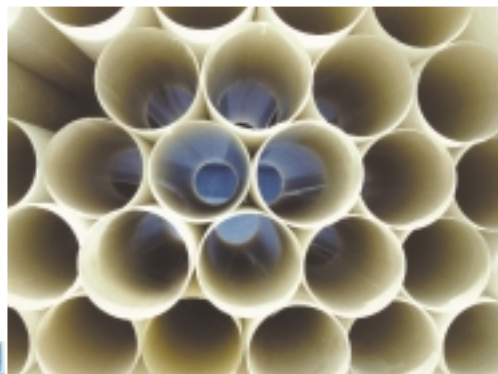

## PVC

Schedule 40 from 1/2" to 24";  
Schedule 80 from 1/4" to 24" and  
SDR (standard dimensional ratio) from 1/2" to 48"

## CPVC

Schedule 40 and 80, 1/2" to 16"

## Xirtec<sup>140</sup>

All Xirtec140 PVC Schedule 40 and 80 pipe shall meet ASTM D 1785 and shall be third party certified to CSA B137.3 or NSF 14.

## CORZAN<sup>™</sup>

All Corzan CPVC Schedule 40 and 80 pipe shall meet ASTM F 441.

See the IPEX Engineering and Specification Manual for more details.

Diameter (in.)	O.D. (in.)	IPEX SCHEDULE 40 PVC/CPVC			IPEX SCHEDULE 80 PVC/CPVC		
		Wall Thickness (in.)	I.D. (in.)	*Max. Pressure 73°F (psi)	Wall Thickness (in.)	I.D. (in.)	*Max. Pressure 73°F (psi)
1/4	.540	n/a	n/a	n/a	.119	.302	1.130
3/8	.675	n/a	n/a	n/a	.126	.423	920
1/2	.840	.109	.602	600	.147	.526	850
3/4	1.050	.113	.804	480	.154	.722	690
1	1.315	.133	1.029	450	.179	.936	630
1 1/4	1.660	.141	1.360	370	.191	1.255	520
1 1/2	1.900	.145	1.590	330	.200	1.476	470
2	2.375	.154	2.047	280	.218	1.913	400
2 1/2	2.875	.203	2.445	300	.276	2.290	420
3	3.500	.216	3.042	260	.300	2.864	370
4	4.500	.237	3.998	220	.337	3.786	320
6	6.625	.280	6.031	180	.432	5.709	280
8	8.625	.322	7.941	160	.500	7.565	250
10	10.750	.365	9.976	140	.593	9.493	230
12	12.750	.406	11.888	130	.687	11.294	230
14	14.000	.438	13.072	130	.750	12.412	220
16	16.000	.500	14.936	130	.843	14.224	220
18	18.000	.562	16.809	130	.937	16.014	220
20	20.000	.593	18.743	120	1.031	17.814	220
24	24.000	.687	22.544	120	1.218	21.418	210

\*Pipe pressure ratings must be devalued for higher temperatures.

# Manual and Actuated Valves

IPEX offers one of the most comprehensive ranges of high quality, high performance valves and strainers available from a single source today. Our quality engineered valves feature unique characteristics ensuring unparalleled reliability. PVC, CPVC, PP and PVDF are all part of our offering with electric as well as pneumatic automation of quarter turn valves and pneumatic for diaphragm valves. Whether a valve is required for isolation, diversion, control or throttling, IPEX has a valve solution to meet your needs.

IPEX offers a complete line of Xirtec140 and Corzan valves for both manual and actuated applications. All Xirtec valves perform at least one of four basic functions – on/off control, throttling, modulating or backflow prevention.

## Selecting the Right Valve

Valves commonly used for on/off service are ball valves and butterfly valves. Throttling or modulating requires diaphragm valves and butterfly valves. Check valves prevent reversal or backflow of fluids in a piping system. When selecting the proper valve to complete a project, it is important to consider the corrosiveness, abrasiveness, and viscosity of the medium, the temperature and pressure of the medium, and the compatibility of the valve seats, weirs, stems, etc. with the flowing medium. The physical space requirements and the weight limitations on the system are also very important.

Another consideration when selecting a valve, is the way in which the valve will be operated in the system. Manually operated valves offer a choice of levers, gears and other handles depending on the size and type. Remotely operated valves can be actuated either electrically or pneumatically.



### PVC

- Compact (ball)
- True Union (ball)
- Three-way (L & T port)
- Check valves (piston, ball, swing)
- Butterfly
- Diaphragm
- Strainers
- Air release
- Actuated



### CPVC

- True Union (ball)
- Check
- Butterfly
- Diaphragm
- Actuated

# Fittings

## Injection Molded Fittings

Injection molded Schedule 40/80 fittings range from 1/4" through 12" for various pressure applications. It is very important to match the pressure capability of the fittings to the operating pressures of the system. In systems with quick-closing valves or cyclic surge conditions, the pressure rating of the fittings should not be calculated at more than 60% of the equivalent pipe. After the two components of the system have been matched, the design engineer may consider additional methods of external reinforcement such as thrust blocks, restraining hangers or encasement. The size or need for such reinforcements should be based on the design engineer's evaluation of flow velocities and pressure increases due to the fluid's momentum.

Xirtec140 injection molded fittings are manufactured in accordance with various ASTM standards and are certified by NSF and conform to CSA B137.3.

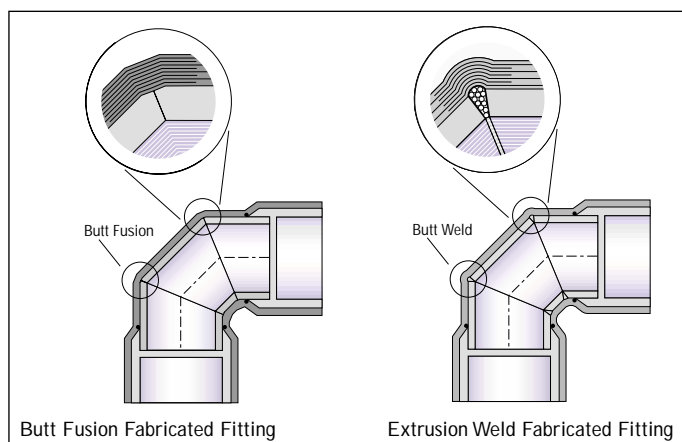

*Note: Other fabrication methods may be used depending on application and service conditions.*

## Fabricated Fittings

Fabricated fittings are high integrity fittings designed and engineered to meet demanding process pipe requirements. Fittings in large pipe sizes (10" to 24") are made from segments of Xirtec140 (PVC) or Corzan (CPVC) pipe welded together or butt fused and reinforced with fiberglass. Custom configurations or standard designs such as tees and elbows are manufactured by these techniques. These fittings, together with IPEX thermoplastic pipe, valves and molded fittings form the complete and unified IPEX vinyl systems.



## Xirtec<sup>140</sup> Schedule 40/80 Industrial Fittings

Xirtec140 Schedule 40 fittings shall conform to ASTM D 2466, Xirtec140 Schedule 80 socket fittings to ASTM D 2467 and ASTM D 2464 for threaded Xirtec140 Schedule 80 fittings.

All fabricated Xirtec140 PVC fittings shall be reinforced with Fiberglass Reinforced Plastic (FRP). Xirtec140 PVC fittings shall be molded or fabricated from PVC (Polyvinyl Chloride) compatible with the Xirtec140 pipe material.

## CORZAN<sup>®</sup> Schedule 40/80 Corzan Industrial Fittings

IPEX Schedule 80 socket fittings shall conform to ASTM F 439 and ASTM F 437 for threaded IPEX Schedule 80 fittings.

All IPEX fabricated CPVC fittings shall be reinforced with Fiberglass Reinforced Plastic (FRP). IPEX CPVC fittings shall be molded or fabricated from Corzan CPVC (Chlorinated Polyvinyl Chloride) compatible with Corzan pipe material.

### PVC

Schedule 40 and 80  
(1/4" to 12" molded; 10" to 24" fabricated)

### CPVC

Schedule 80  
(1/4" to 12" molded; 14" to 16" fabricated)

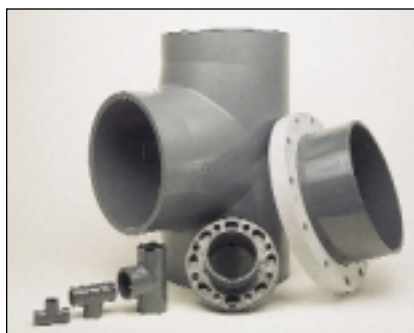

## SALES AND CUSTOMER SERVICE

Canadian Customers call

Toll free: (866) 473-9462

U.S. Customers call

Toll free: (800) 463-9572

[www.ipexinc.com](http://www.ipexinc.com)

### About IPEX

IPEX is a leading supplier of thermoplastic piping systems. We provide our customers with one of the world's largest and most comprehensive product lines. All IPEX products are backed by over 50 years of experience. With state-of-the-art manufacturing facilities and distribution centers across North America, the IPEX name is synonymous with quality and performance.

Our products and systems have been designed for a broad range of customers and markets. Contact us for information on:

- PVC, CPVC, PP, ABS, PEX and PE pipe and fittings (1/4" to 48")
- Industrial process piping systems
- Double containment systems
- Acid waste systems
- High purity systems
- Municipal pressure and gravity piping systems
- Plumbing and mechanical piping systems
- PVC electrical systems
- Telecommunications and utility piping systems
- Irrigation systems
- Radiant heating systems

**IPEX. Your industrial specialist.**

**We build tough products for tough environments™.**

**WARRANTY:** All IPEX products are guaranteed against defects resulting from faulty workmanship or materials. If any such product is found to be defective by reason of faulty workmanship or materials, upon written notice and return of the product, the defective product will be replaced by IPEX free of charge, including shipping charges for the replacement product. Claims for labor costs and other expenses required to replace such defective product or to repair any damage resulting from the use thereof will not be allowed by IPEX. Our liability is limited to the price paid for the defective product. IPEX will not be bound by any warranty, other than above set forth, unless such warranty is in writing.

This literature is published in good faith and is believed to be reliable. However IPEX does not represent and/or warrant in any manner the information and suggestions contained in this brochure. Data presented is the result of laboratory tests and field experience.

IPEX maintains a policy of ongoing product improvement. This may result in modifications of features and/or specifications without notice.

BRINNAIP011216  
© 2002 IPEX IND0022UC



**IPEX**  
Committed to Excellence

